

APsystems Microinverter User Manual

APsystems EZ1 series Microinverters

(For EMEA)



ALTENERGY POWER SYSTEM Inc.
emea.APsystems.com

APsystems

Karspeldreef 8, 1101 CJ Amsterdam, The Netherlands
EMAIL: info.emea@APsystems.com

APsystems

22 Avenue Lionel Terray, 69330 Jonage, France
EMAIL: info.emea@APsystems.com

© All Rights Reserved



Please scan this QR code to have access to our APPs and Products Information.

Table of Contents

1. Important Safety Instructions	2
1.1 Safety Instructions.....	2
1.2 Radio Interference Statement.....	3
1.3 Symbols in lieu of words.....	4
2. APsystems Microinverter System Introduction	5
3. APsystems Microinverter EZ1 series Introduction	7
4. APsystems Microinverter System Installation	8
4.1 Additional accessories supplied by APsystems.....	8
4.2 Installation Procedures.....	8
4.2.1 Step 1 - Verify that grid voltage matches microinverter rating.....	8
4.2.2 Step 2 - Install the microinverters in proper position.....	8
4.2.3 Step 3 - Connect APsystems microinverters to the PV Modules.....	8
4.2.4 Step 4 - Connect the APsystems microinverter to power cord.....	9
4.2.5 Step 5 - Insert the power cord into the socket.....	10
5. Install and Use AP EasyPower	11
5.1 Install APP.....	11
5.2 Connect the APsystems Microinverters.....	11
5.3 Monitor & Control.....	12
6. Troubleshooting	13
6.1 Status Indications and Error Reporting.....	13
6.1.1 Start up LED.....	13
6.1.2 Operation LED.....	13
6.1.3 GFDI Error.....	13
6.2 Trouble Shooting Guide.....	13
6.3 APsystems Technical Support.....	13
6.4 Maintenance.....	13
7. Replace a microinverter	14
8. Technical Data	15
8.1 EZ1 series Microinverter Datasheet.....	16
9. EZ1 Series PV Capacity Expansion Introduction	18
10. EZ1 Accessory	19

1. Important Safety Instructions

This manual contains important instructions to follow during installation and maintenance of the APsystems Photovoltaic Grid-connected Microinverter. To reduce the risk of electrical shock and ensure a safe installation and operation of the APsystems Microinverter, the following symbols appear throughout this document to indicate dangerous conditions and important safety instructions.

Specifications are subject to change without notice. Please ensure you are using the most recent update found at <https://emea.apsystems.com/resources/library/>

WARNING:

This indicates a situation where failure to follow instructions may cause a serious hardware failure or personnel danger if not applied appropriately. Use extreme caution when performing this task.

NOTICE:

This indicates information that is important for optimized microinverter operation. Follow these instructions closely.

1.1 Safety Instructions

- ✓ Perform all electrical installations in accordance with local electrical codes.
- ✓ Before installing or using the APsystems Microinverter, please read all instructions and cautionary markings in the technical documents and on the APsystems Microinverter system and the solar array.
- ✓ **Do NOT** disconnect the PV module from the APsystems Microinverter without first disconnecting the AC power.
- ✓ Be aware that the body of the APsystems Microinverter is the heat sink and can reach a temperature of 80°C. To reduce risk of burns, do not touch the body of the Microinverter.
- ✓ **Do NOT** attempt to repair the APsystems Microinverter. If the microinverter is suspected to be faulty, please contact your local APsystems Technical Support to start troubleshooting and obtain a RMA (Return Merchandise Authorization) number to start the replacement process if needed. Damaging or opening the APsystems Microinverter will void the warranty.

1. Important Safety Instructions

1.2 Radio Interference Statement

EMC Compliance: The APsystems Microinverter can radiate radio frequency energy. If not installed and used in accordance with the instructions, it may cause harmful interference to radio communication.

APsystems Microinverter complies with EMC regulations, which are designed to provide reasonable protection against harmful interference in a residential installation.

Nonetheless, if the Microinverter does cause interference to radio or television reception, you are encouraged to try to correct the interferences by one of more of the following measures:

- A) Increase the separation between the Microinverter and the receiver
- B) Connect the Microinverter into an outlet on a circuit different from that to which the receiver is connected

If none of the recommendations suggested above bring significant improvement in terms of interferences, please contact your local APsystems Technical Support.

Hereby, [ALTENERGY POWER SYSTEM INC.] declares that the radio equipment type [EZ1-M, EZ1-H] is in compliance with Directive 2014/53/EU.

The full text of the EU declaration of conformity is available at the following internet address:
<https://emea.apsystems.com/resources/library/>

1. Important Safety Instructions

1.3 Symbols in lieu of words

 **APsystems** Trademark.



Caution, risk of electric shock.



Caution, hot surface.



Symbol for the marking of electrical and electronics devices according to Directive 2002/96/EC. Indicates that the device, accessories and the packaging must not be disposed as unsorted municipal waste and must be collected separately at the end of the usage. Please follow Local Ordinances or Regulations for disposal or contact an authorized representative of the manufacturer for information concerning the decommissioning of equipment.



CE mark is attached to the solar inverter to verify that the unit follows the provisions of the European Low Voltage and EMC Directives.



Refer to the operating instructions.

Qualified personnel

Person adequately advised or supervised by an electrically skilled person to enable him or her to perceive risks and to avoid hazards which electricity can create. For the purpose of the safety information of this manual, a "qualified person" is someone who is familiar with requirements for safety, electrical system and EMC and is authorized to energize, ground, and tag equipment, systems, and circuits in accordance with established safety procedures. The inverter and photovoltaic system may only be commissioned and operated by qualified personnel.

2. APsystems Microinverter System Introduction

The EZ1 series APsystems Microinverter is used in balcony and DIY systems which comprised of the below key elements (The EZ1 series is not suitable for the rooftop system application scenario.) :

- PV modules
- Power Cord
- EZ1 series microinverter
- Router
- Cell phone

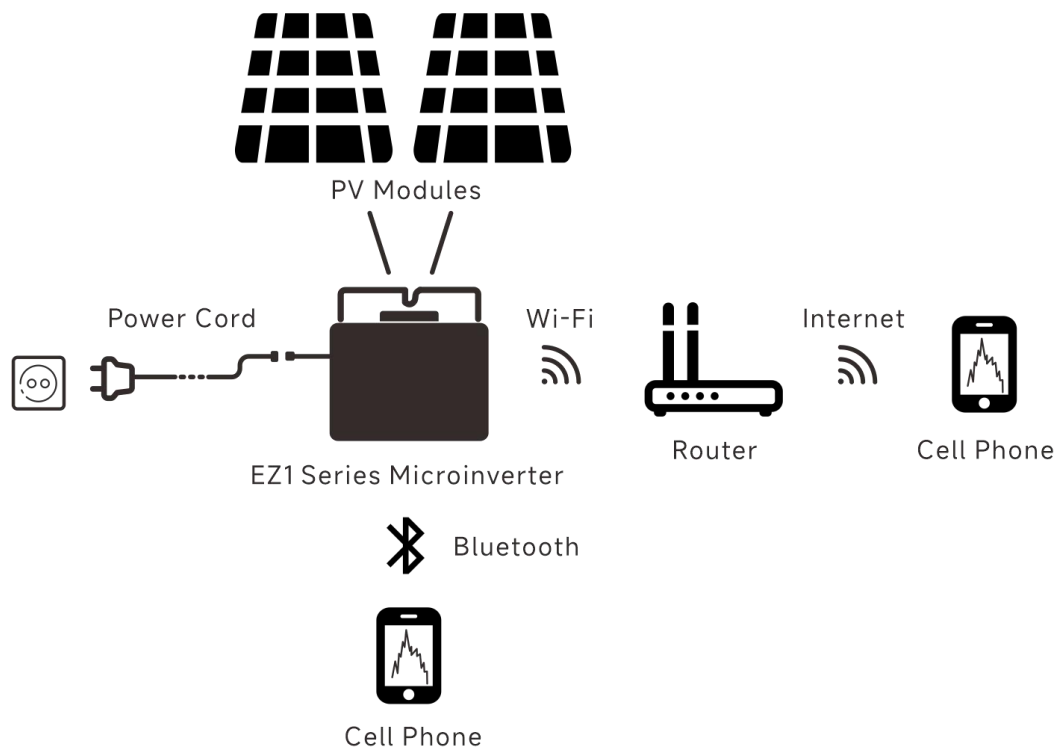

EZ1 series microinverters have 2 input channels with independent MPPT and high input current and output power to adapt to today's larger power module. Users could directly connect to the EZ1 with their cell phones through Bluetooth and get the real-time data of the solar systems. Besides direct connection, EZ1 could also connect to a router through Wi-Fi and send data to cloud servers for remote monitoring.

Through an AC extension cable provided by APsystems, EZ1 could be plugged into a socket and start output energy, truly easy and convenient grid connection.

1. If the wireless signal in the area where the microinverter is weak, it is necessary to add a Wi-Fi signal booster at a suitable place between the router and the microinverter.



2. The EZ1 series product is only suitable for the following DIY application scenarios, such as balcony, garden, garage, and carport. The EZ1 series is not suitable for the rooftop system application scenario.

3. The EasyPower App supports monitoring up to 4 products from the EZ1 series. In Germany, the maximum power for plug-in PV systems is 800W, otherwise a professional electrician or installer is needed..

4. If the microinverter is connected to grid by plug, please comply with the local regulation about the power limit.

2. APsystems Microinverter System Introduction

This integrated system improves safety; maximizes solar energy harvest; increases system reliability, and simplifies solar system design, installation, maintenance, and management.

Safety with APsystems Microinverters

In a typical string inverter installation, PV modules are connected in series. The voltage adds-up to reach high voltage value (from 600Vdc up to 1000Vdc) at the end of the PV string. This extreme high DC voltage brings a risk of electrical shocks or electrical arcs which could cause fire.

When using an APsystems microinverter, PV modules are connected in parallel. Voltage at the back of each PV module never exceeds PV modules Voc, which is lower than 60Vdc for most of PV modules used with APsystems microinverters. This low voltage negates the risk of electrical shock, electrical arcs and fire hazards.

APsystems Microinverters maximize PV energy production

Each PV module has individual Maximum Peak Power Tracking (MPPT) control, which ensures that the maximum power is produced to the utility grid regardless of the performance of the other PV modules in the array. When PV modules in the array are affected by shade, dust, different orientation, or any situation in which one module underperforms compared with the other units, the APsystems Microinverter ensures top performance from the array by maximizing the performance of each module individually within the array.

More reliable than centralized or string inverters

APsystems Microinverters are designed to operate at full power at ambient outdoor temperatures of up to 65 deg C (or 149 F). The inverter case is designed for outdoor installation and complies with the IP67 environmental enclosure rating.

Simple to install

EZ1 series micorinverters have 2 input channels with independent MPPT and high input current and output power to adapt to today's larger power module. Users could directly connect to the EZ1 with their cell phones through Bluetooth and get the real-time data of the solar systems. Besides direct connection, EZ1 could also connect to a router through Wi-Fi and send data to cloud servers for remote monitoring.

Through an AC extension cable provided by APsystems, EZ1 could be plugged into a socket and start output energy, truly easy and convenient grid connection

3. APsystems Microinverter EZ1 series Introduction

Key Product Feature:

- One microinverter connects to two modules with independent MPPT
- Max output power reaching 600VA or 799VA for different models
- High Input current to adapter to large modules
- Maximum reliability, IP67
- Built in Wi-Fi and Bluetooth
- Safety protection relay integrated
- Dedicated for balcony and DIY systems
- Directly plug into wall socket

4. APsystems Microinverter System Installation

4.1 Additional accessories supplied by APsystems

- EZ1 power cord

4.2 Installation Procedures

4.2.1 Step 1 - Verify that grid voltage matches microinverter rating

Do NOT carry the microinverter by the AC cable. This may cause the AC cable to partially or fully disconnect from the unit, resulting in no or poor operation.

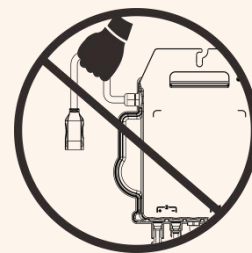

4.2.2 Step 2 - Install the microinverters in proper position

The Microinverter EZ1 can be installed on the balcony wall or fixed to the railing using cable ties. Select an appropriate installation method based on your actual scenario to ensure that the EZ1 is securely installed.

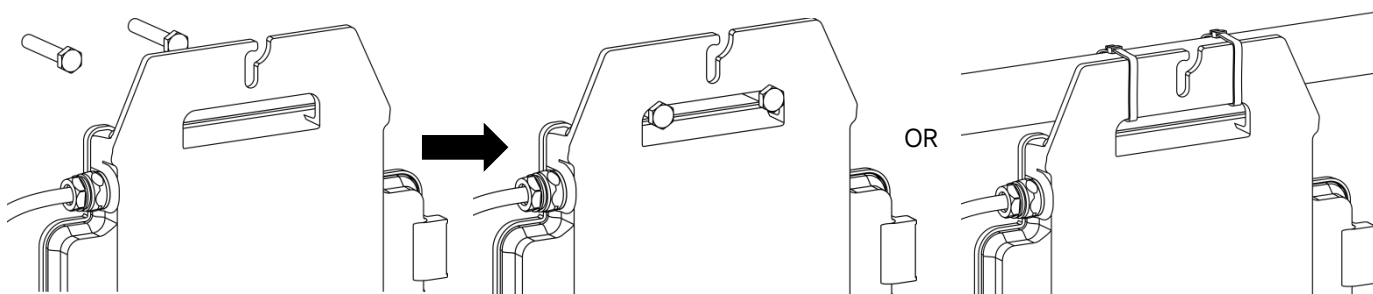

Install the microinverters in proper position to avoid direct exposure to rain, UV or other harmful weather events.

4.2.3 Step 3 - Connect APsystems microinverters to the PV Modules

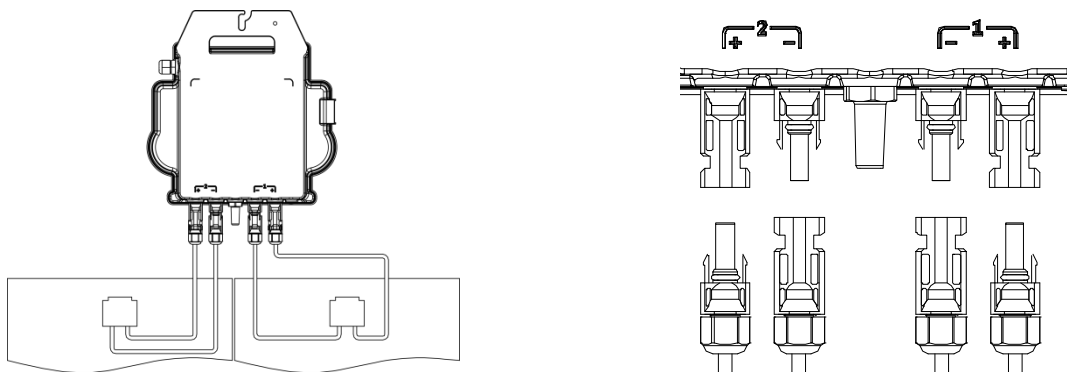

When plugging in the DC cables, the microinverter should immediately blink green ten times. This will happen as soon as the DC cables are plugged in and will show that the microinverter is functioning correctly. This entire check function will start and end within 10 seconds of plugging in the unit, so pay careful attention to these lights when connecting the DC cables.

4. APsystems Microinverter System Installation

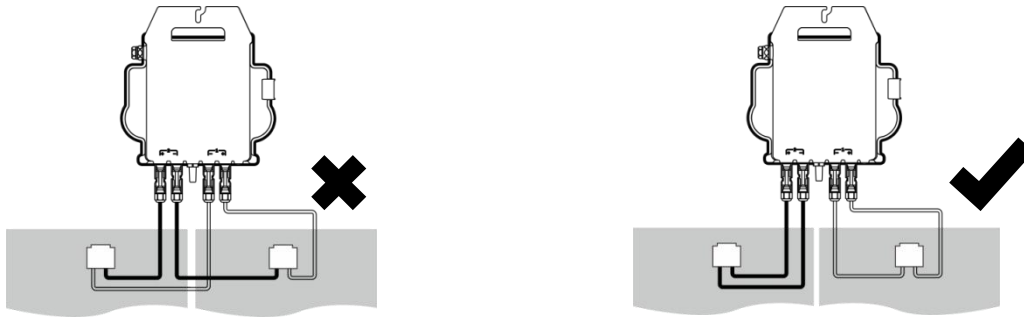

1. Each PV panel must be carefully connected to the same channel.
Make sure to not split positive and negative DC cables into two different input channels: microinverter will become damaged and warranty will not apply.
2. Please ensure each DC cable's length within 3 meters.

4.2.4 Step 4 - Connect the APsystems microinverter to power cord



1. Remove the bus cable Y-CONN protective sleeve before power cord connection.
2. If the dual parallel bus cable and power cord are not included in the package and should be purchased separately. Please contact the salesperson or your dealer for details.

Best Practice: Use the Unlock Tool to disconnect the connectors. (The Unlock Tool is included in the package, please safekeeping.)

Single device: Insert the microinverter AC connector into the power cord connector. Make sure to hear the “click” as a proof of robust connection.

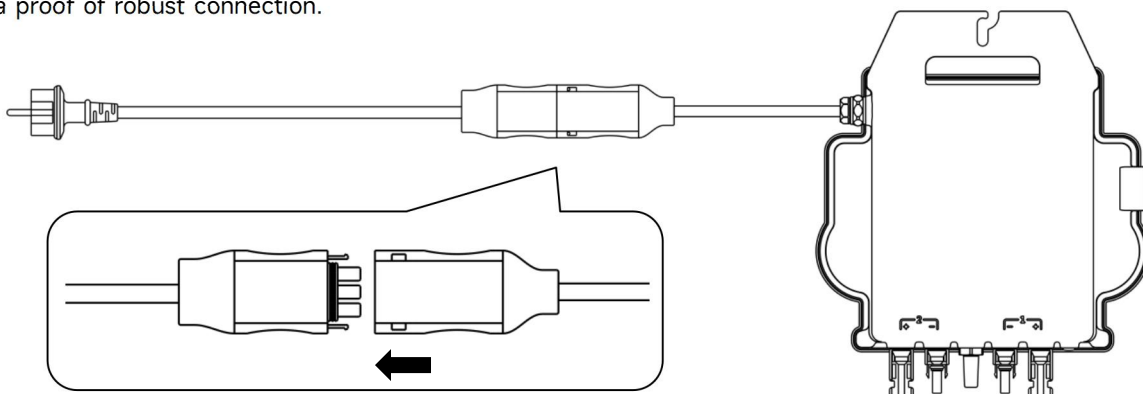

4. APsystems Microinverter System Installation

Two device: The microinverter can also have two units connected in parallel to the power line.

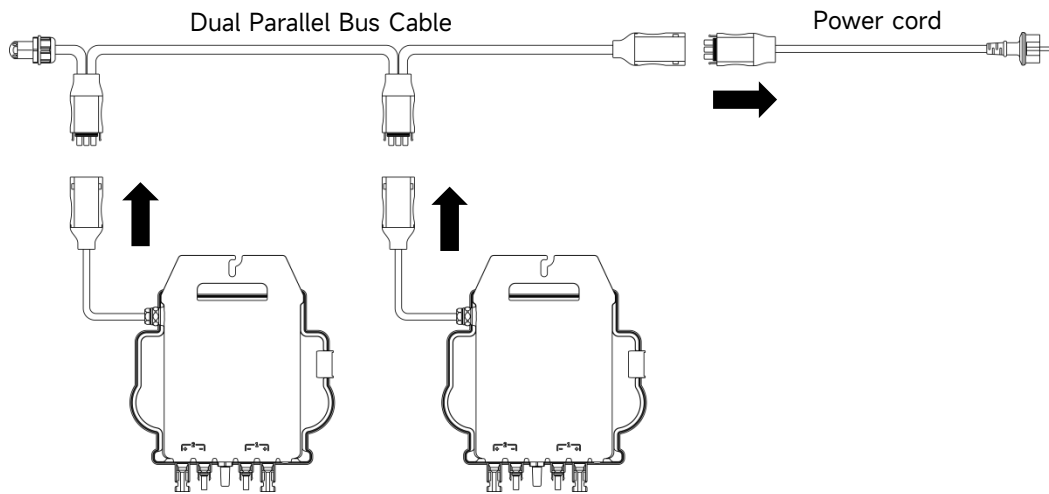

4.2.5 Step 5 - Insert the power cord into the socket

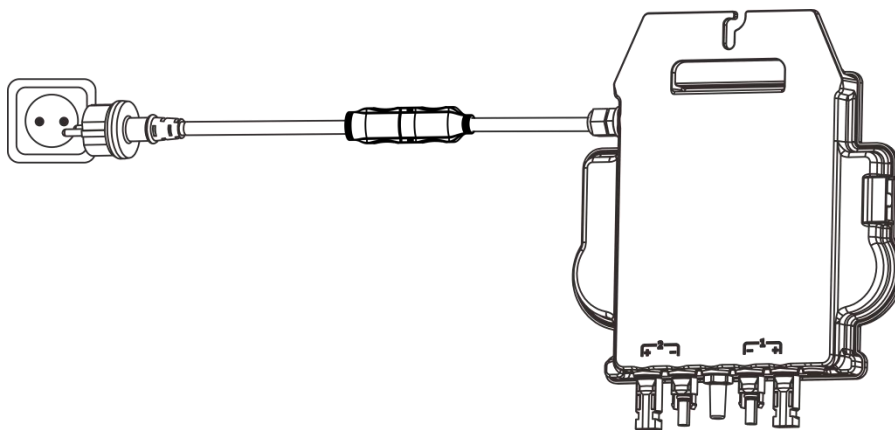

If the microinverter is connected to grid by plug, please comply with the local regulation about the power limit.

5. Install and Use AP EasyPower

5.1 Install APP

Please scan QR code below to have access to our products and APP catalogue, or click this link to download our APPs: <https://file.apssystemsema.com:8083/apssystems/apeasypower/download.html> .



iOS:

- Go to App Store
- Search “AP EasyPower”
- Download and install

iOS: 10.0 and up.

Android:

Method 1

- Go to Google Play Store
- Search “AP EasyPower”
- Download and install

Method 2

- Open <https://apssystems.com>
- Select your region
- Click the tab menu “Apps” below “Products”
- Download and install

Android: 7.0 and up.

5.2 Connect the APsystems Microinverters

AP EasyPower offers two modes “Direct Connect Mode” and “Remote Mode” to monitor the device.

Direct Connect Mode: APP connects to Bluetooth of the device, so that users can realize local monitoring and control of the device.

Remote Mode: Login account, users can realize remote monitoring and control of the device.

1. In the absence of Wi-Fi, users can monitor and control the device in direct connection mode.

2. You are able to link up to 4 devices to your account, just repeat the linking device operations until linking all your devices. If the microinverter is connected to grid by plug, please comply with the local regulation about the power limit. In Germany, the maximum power for plug-in PV systems is 800W, otherwise a professional electrician or installer is needed.

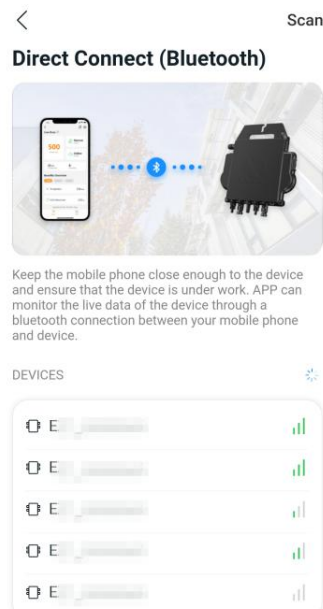
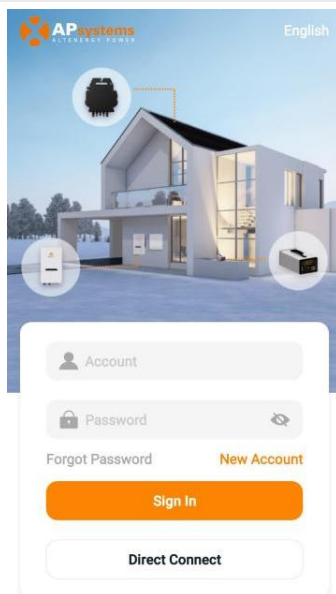

5. Install and Use AP EasyPower

5.3 Monitor & Control

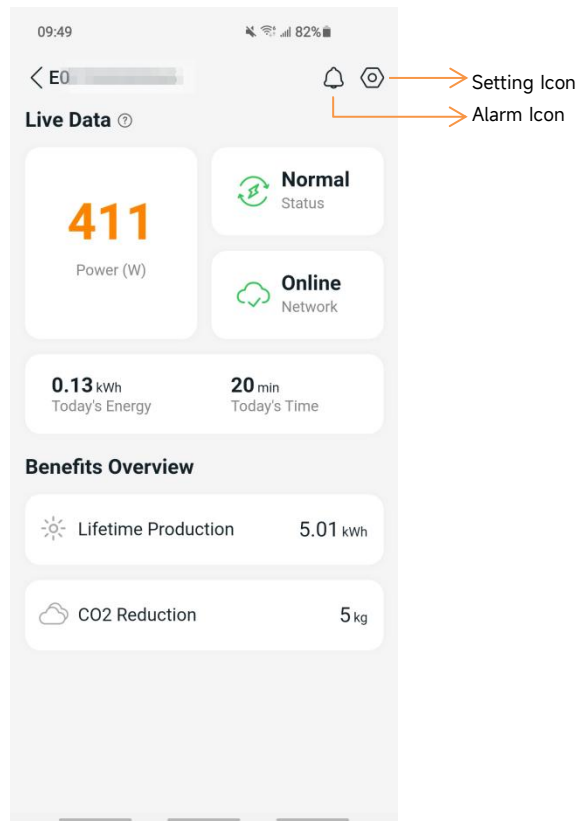

On this page, user can visualize

- **Live Data:** The real-time data of the device in current round, including the power, energy, running time, working status and the cloud status.
 - Working status
 - Normal:** The device is working normally.
 - Alarm:** The device has alarms and you need to check it.
 - Cloud status
 - Online:** The device is connecting the cloud service through the internet.
 - Offline:** The device is not connecting the cloud service through the internet, maybe the device is not connected the Wi-Fi or the router is down.
 - **Benefits Overview:** The lifetime energy produced by the device and the equivalent CO2 reduction.
- By pressing “**alarm icon**” to check the alarm information if the device status is alarm.
By pressing “**setting icon**” to set the device. The setting page is shown below.

For Connection and monitoring operation mode, please refer to the AP EasyPower User Manual.

6. Troubleshooting

Users can use the following troubleshooting steps if the PV system does not operate correctly:

6.1 Status Indications and Error Reporting

Assuming they are easily accessible and visible, Operation LEDs can give a good indication of the microinverters status

6.1.1 Start up LED

Ten short green blinks when DC power is first applied to the Microinverter indicates a successful Microinverter startup.

6.1.2 Operation LED

Flashing Slow Green (5 sec. gap) - Producing power and the Microinverter is in normal working status.

Flashing Slow Red (5 sec. gap) - The Microinverter is in protection status or disconnected from grid.

6.1.3 GFDI Error

A solid red LED indicates the Microinverter has detected a Ground Fault Detector Interrupter (GFDI) error in the PV system. Please check if the DC inputs of the inverter are mistakenly connected to ground or contact your local APsystems Technical Support.

6.2 Trouble Shooting Guide

Professional Users can also refer to our Troubleshooting Guide (<https://emea.apsystems.com/resources/library/>, section libraries) for more in depth guidelines on how to troubleshoot and fix PV installations powered by APsystems microinverters.

6.3 APsystems Technical Support

The APsystems local Technical Support team is available to support professional installers in becoming familiar with our products and to troubleshoot installations when needed.

Do not attempt to repair APsystems Microinverters. Please contact your local APsystems Technical Support.

- ①. Never disconnect the DC wire connectors under load. Ensure that no current is flowing in the DC wires prior to disconnecting.
- ②. Always disconnect AC power before disconnecting the PV module wires from the APsystems Microinverter.
- ③. The APsystems Microinverter is powered by PV module DC power. AFTER disconnecting the DC power, when reconnecting the PV modules to the Microinverter, be sure to watch for the ten short green LED flashes.

6.4 Maintenance

APsystems microinverters do not require any specific regular maintenance.

7. Replace a microinverter

Follow the procedure to replace a failed APsystems Microinverter

- A. Disconnect the APsystems Microinverter from the PV Module, in the order shown below:
 - 1. Disconnect the inverter from grid
 - 2. Disconnect the PV module DC wire connectors from the microinverter.
 - 3. Remove the Microinverter from the PV array racking.

- B. Install a replacement Microinverter to the rack. Remember to observe the flashing green LED light as soon as the new Microinverter is plugged into the DC cables.

- C. Insert the microinverter AC connector into the power cord connector.

- D. Connect the inverter to grid and verify proper operation of the replacement Microinverter.

8. Technical Data

- ①. Be sure to verify that the voltage and current specifications of your PV module are compatible with the range allowed on APsystems Microinverter. Please check the microinverter datasheet and Module Compatibility Calculator: <https://apsystems.com/wp-content/uploads/module-compatibility-calculator/module-compatibility-calculator-for-EZ1.html?area=EMEA&flag=English> .
- ②. DC operating voltage range of the PV module must be within allowable input voltage range of the APsystems Microinverter.
- ③. The maximum open circuit voltage of the PV module must not exceed the specified maximum input voltage of the APsystems.

8.1 EZ1 series Microinverter Datasheet

Model	EZ1-M	EZ1-H
Input Data (DC)		
Recommended PV Module Power (STC) Range	300Wp-730Wp+	410Wp-760Wp+
Peak Power Tracking Voltage		28V-45V
Operating Voltage Range		26V-60V
Maximum Input Voltage		60V
Maximum Input Current		20A x 2
Isc PV		25A x 2
Maximum Inverter Backfeed Current To Array		0A
Output Data (AC)		
Maximum Continuous Output Power	600VA ⁽¹⁾ / 799VA	960VA
Nominal Output Voltage/Range		230V/184-253V
Nominal Output Current	2.6A ⁽¹⁾ / 3.5A	4.2A
Nominal Output Frequency/ Range		50Hz/48Hz-51Hz
Power Factor		0.99
Inrush Current		11.92A
Maximum Output Fault Current		34A
Maximum Output Overcurrent Protection		10A
Wi-Fi Frequency Range		2412MHz - 2472MHz
Wi-Fi Maximum Power (EIRP)		19.86dBm
Bluetooth Frequency Range		2402MHz - 2480MHz
Bluetooth Maximum Power (EIRP)		18.18dBm
Efficiency		
Peak Efficiency		96.7%
Nominal MPPT Efficiency		99.5%
Night Power Consumption		20mW
Mechanical Data		
Operating Ambient Temperature Range		-40 °C to +65 °C
Storage Temperature Range		-40 °C to +85 °C
Dimensions (W x H x D)	263mm x 218mm x 36.5mm	263mm x 218mm x 37mm
Weight	2.8kg	3kg
DC Connector Type		MC4 Compatible
Cooling		Natural Convection - No Fans
Enclosure Environmental Rating		IP67
Pollution Degree Classification		PD3
Operate Relative Humidity Range		4%~100%
Maximum Altitude		<2000m
Overvoltage Category		OVC II For PV Input Circuit, OVC III For Mains Circuit

8.1 EZ1 series Microinverter Datasheet

Power Cord(Optional)

Wire Size	2.5mm ²
Cable Length	4M as default
Plug Type	Schuko ⁽²⁾

Features

Communication	Built-in Wi-Fi and Bluetooth
Maximum Units Can Be Connected ⁽³⁾	2
Isolation Design	High Frequency Transformers, Galvanically Isolated
Energy Management ⁽⁴⁾	AP EasyPower APP
Warranty ⁽⁵⁾	12 Years Standard

Compliances

Safety, EMC & Grid Compliances	EN/IEC 62109-1; EN/IEC 62109-2; EN IEC 61000-6-1; EN IEC 61000-6-2; EN IEC 61000-6-3; EN IEC 61000-6-4; EN IEC 61000-3-2; EN 61000-3-3; EN 55011; EN 62920; EN 50549-1;EN 50549-10;NF EN 50549-1;NF EN 50549-10; PN-EN 50549-1; IRIESD; CEI 0-21; VDE-AR-N 4105; UTE C15-712-1; VFR 2019; UNE 217002; RD 647; RD 413; RD 1699; G98; G99; G98/NI; G99/NI
--------------------------------	---

(1)The factory setting could be 600VA as default.

(2)If the microinverter is connected to grid by plug, please comply with the local regulation about the power limit.

(3)For some countries it is limited to 1 because of the regulations.

(4)The EasyPower App supports monitoring up to 4 units of product from the EZ1 series. In Germany, the maximum power for plug-in PV systems is 800W, otherwise a professional electrician or installer is needed.

(5)Support and warranty is not available for rooftop installation systems.

(6)APsystems' Microinverter Systems fully meet the rapid shutdown requirement without the need to install additional electrical equipment.

9. EZ1 Series PV Capacity Expansion Introduction

For balcony systems in DIY applications, it happens often that the PV modules produce less power than expected because of reasons such as improper installation angle. Sometimes it can be less than half of the rated output power. Many customers would like to increase the system power by connecting more PV modules. APsystems DIY microinverters EZ1 series, with large input current of 20A, offer a safe and reliable solution.

EZ1 series has the rated output power of 799W. Each channel can connect to 2 PV modules. In total, EZ1 series can connect to a maximum of 4 PV modules. See the below wiring diagrams for EZ1-M.

EZ1-M Wiring Diagram

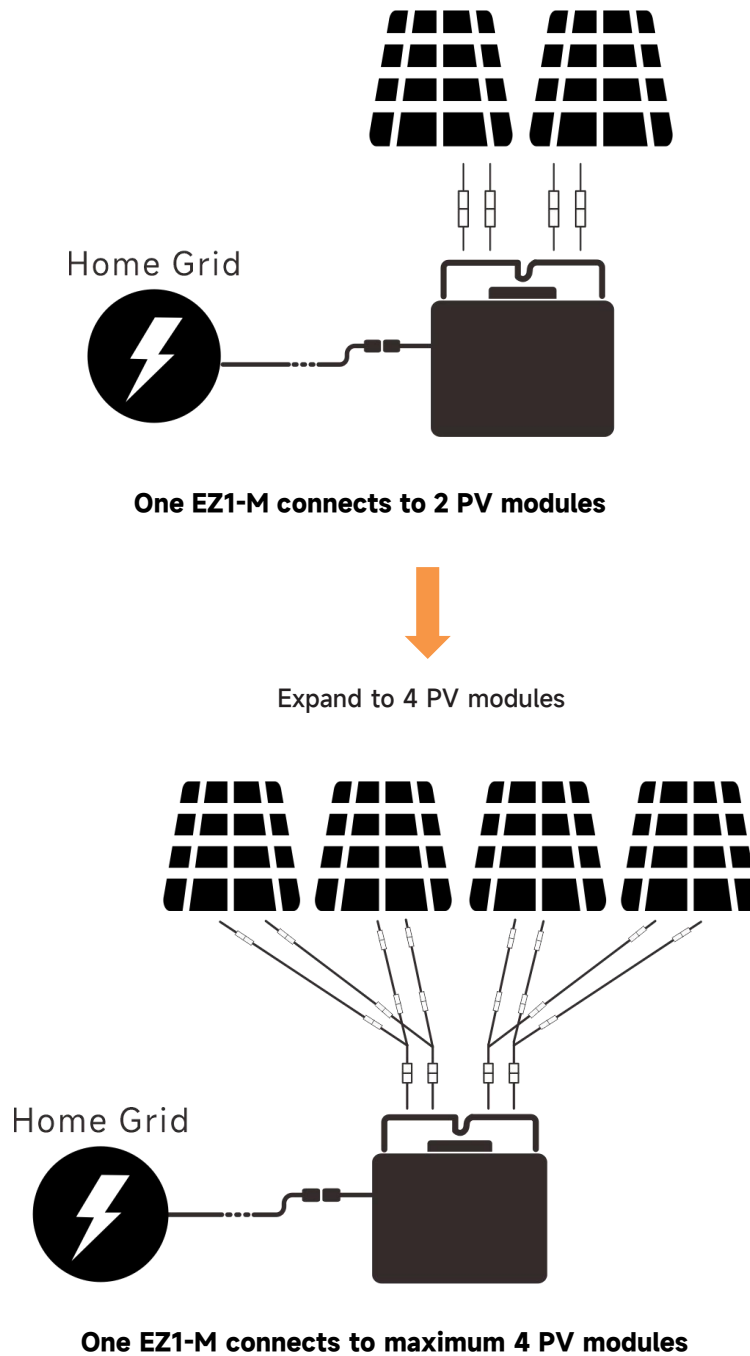

Note:

1. For the PV capacity expansion usage, suggest to use the PV modules with STC power not more than 450W.
2. Customers can purchase by themselves DC extension cables, and 2-to-1 cables or connectors.
3. If the microinverter is connected to grid by plug, please comply with the local regulation about the power limit.

10. EZ1 Accessory

10.1 Dimensions

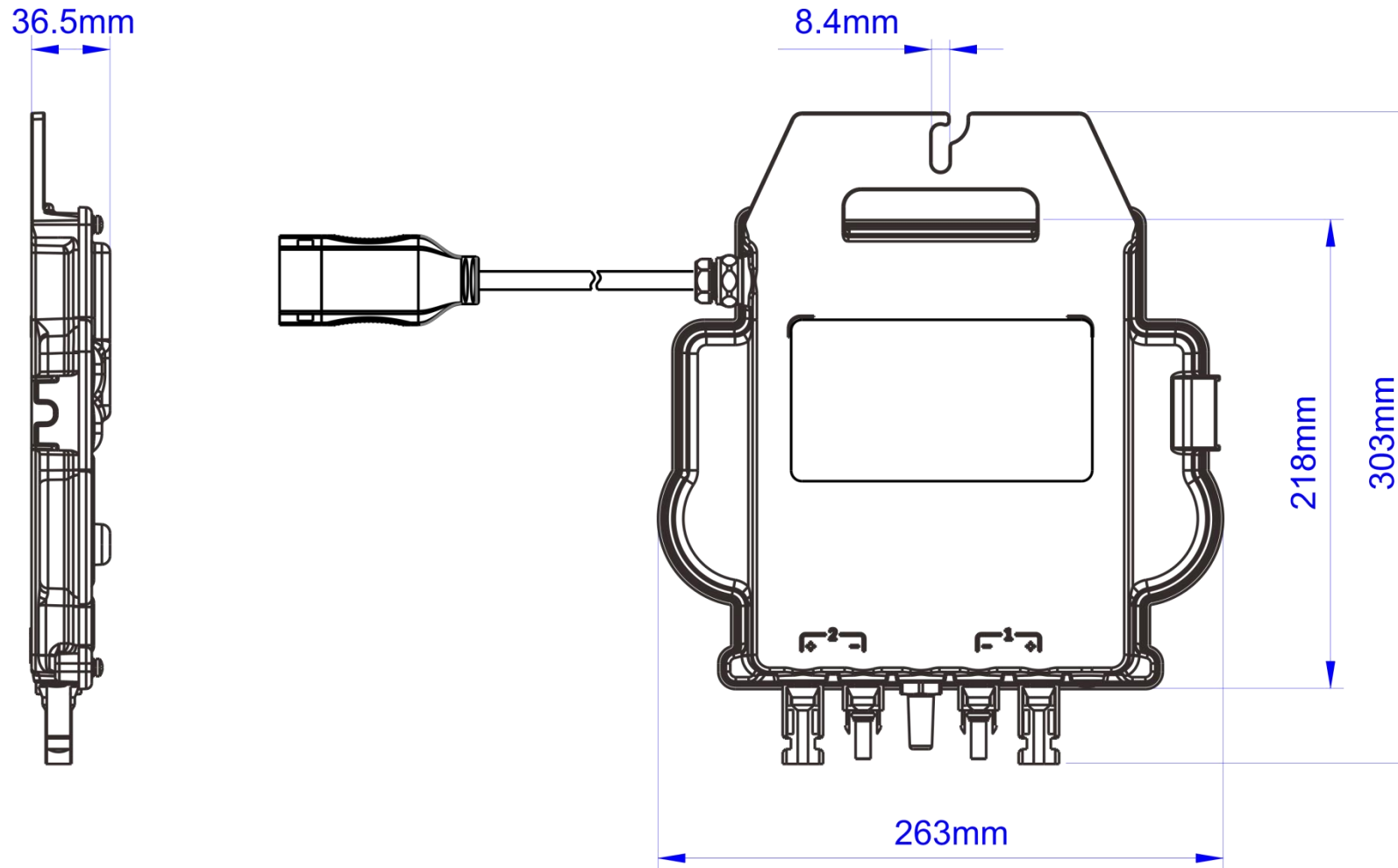

10. EZ1 Accessory

10.2 Single Device

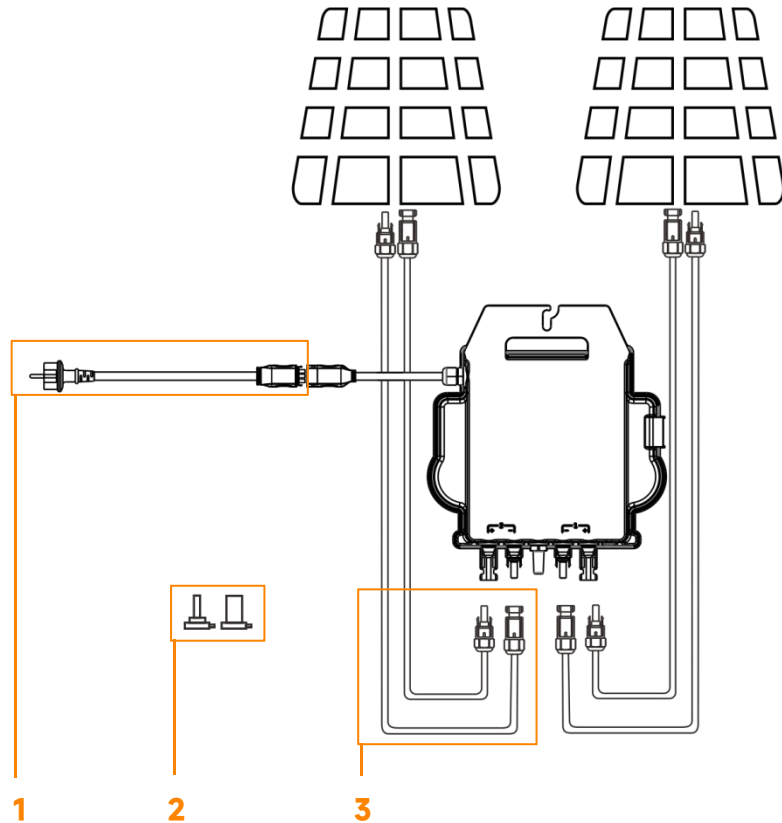

10.3 Multiple Devices

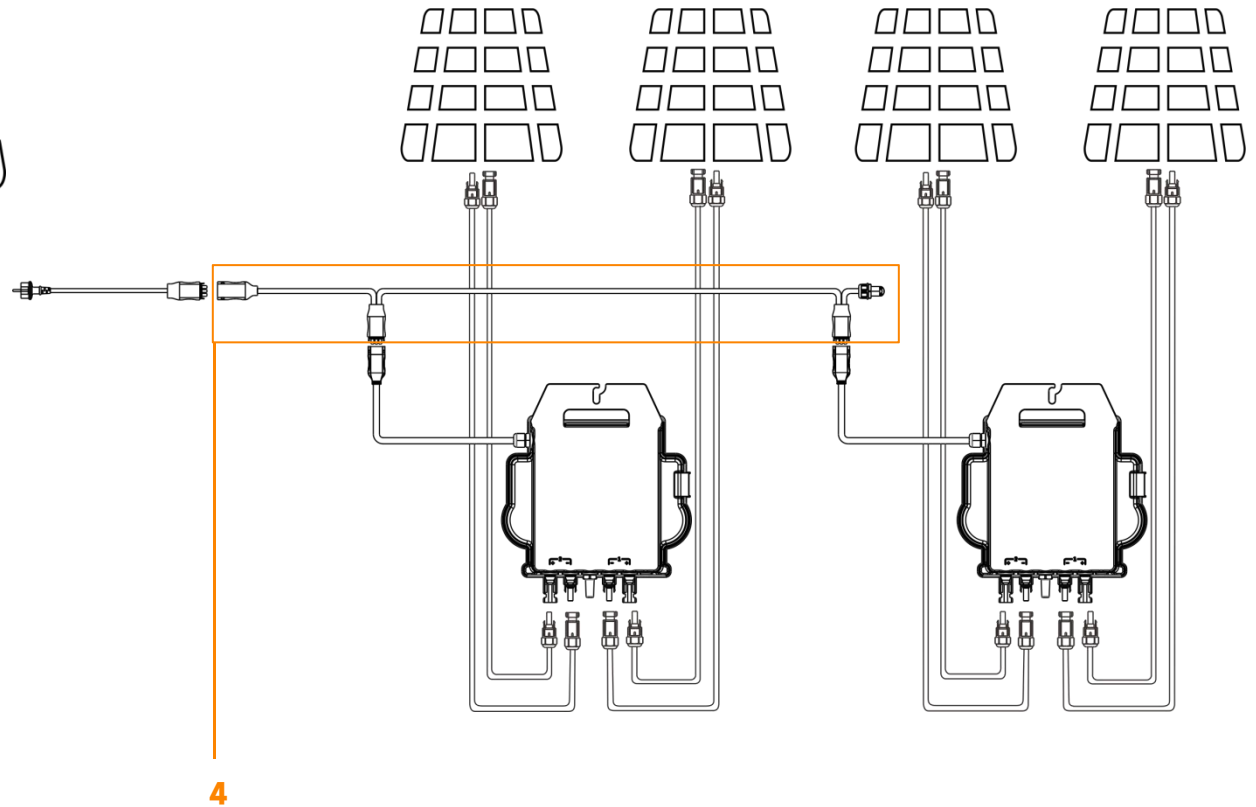

1	2	3	4
Power Cord (Optional)	DC Male /Female Connector Cap (Optional)	DC Extension Cable (Optional)	Bus Cable (Optional)
EZ1 power cord (2.5mm ² ,1m/4m/10m)	DC Male /Female Connector Cap(MC4)	2m DC Extension Cable (MC4)	Dual ParallelBus Cable (2.5mm ² ,2m/4m)